

MODEL 4052

Pump-Down Controller

- 4-20mA Input/Scalable Output
- Seal Fail Monitoring
- Duplex Pump Alternation
- Hand-Off-Auto Controls
- Dual Run-time Meters
- RS-485/Modbus Communications

DESCRIPTION

The Model 4052 Pump-Down Controller provides total control for duplex pumping systems. The Model 4052 monitors, controls and displays the liquid level in a tank or reservoir. Maximum selectable depth is from 11.5 ft. to 346 ft.

The input to the Model 4052 can be from any 2 or 3-wire transducer with a 4-20mA output representing the selected depth. A 24VDC regulated probe supply is included. A Level Simulator is provided to aid in programming these five set points; Low Alarm, Pumps Off, Level 1, Level 2 and High Alarm.

A universal zero to 30 second On Delay can be programmed to prevent outputs from closing due to input fluctuations caused by turbulent conditions. An additional 4-20mA output with zero and span controls is provided for a chart recorder or other external device.

Four heavy-duty 10 amp, 120V contacts are provided for pump control and alarm activation. An auto-dialer or other emergency device can be activated with the SPDT power loss relay. This relay is held open when power is applied.

Pump outputs include duplex alternation as well as hand-off-auto switches. Pump run-time can be displayed for each pump with tenth of an hour resolution, up to 99,999.9 hours. The Model 4052 can be panel-mounted (11 1/8" x 4 5/8) or surface-mounted using the optional surface-mounting kit (Model 4000).



SPECIFICATIONS

MODEL	4052
Input Voltage	120VAC ± 10% 50/60Hz
Pwr Consumption	8W max.
Signal Input	4-20mA (optional 0-5V), 2 or 3 wire
Signal Input Load	250 ohms max.
Dead Band	1% of full scale
Repeat Accuracy	± 1% of scaled max. (fixed conditions)
Display Type	6 digit red LED display
Display Ranges	Level: 00.0 to 346 ft Runtime: zero to 99,999.9 hours Delay: zero to 30 seconds
Display Resolution	1 decimal place
Control Contacts	4 SPDT 10A at 120VAC resistive
Power Loss Relay	1 SPDT 5A at 120VAC resistive
Signal Output	Output is factory set to track the 4-20mA input. Zero and span adjustments are provided: as little as a 2mA change can cause a full swing of the output.
Signal Output Load	300 ohms max.
Probe Supply	24VDC regulated
Setpoints	3 levels, 2 alarms, all user-adjustable
Operating Temp	+14° to +122° F
Humidity Tolerance	0-97% w/o condensation
Enclosure Material	16 gauge steel
Termination	removable terminal strips
Dimensions	H: 5.5" W: 12.0" D: 4.75"
Weight	6.0 pounds
Agency Approvals	UL Recognized (U.S. & Canadian)

DIMENSIONS

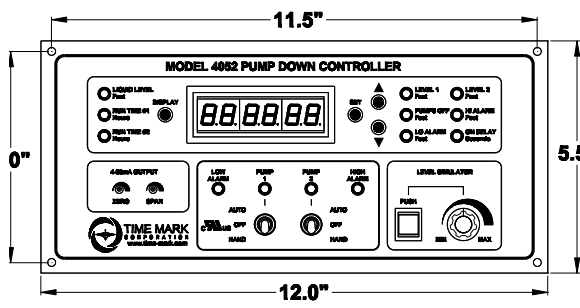

MODEL 4052 Pump Down Controller

READ ALL INSTRUCTIONS BEFORE INSTALLING, OPERATING OR SERVICING THIS DEVICE.
KEEP THIS DATA SHEET FOR FUTURE REFERENCE.

GENERAL SAFETY

POTENTIALLY HAZARDOUS VOLTAGES ARE PRESENT AT THE TERMINALS OF THE MODEL 4052.
ALL ELECTRICAL POWER SHOULD BE REMOVED WHEN CONNECTING OR DISCONNECTING WIRING.
DO NOT EXCEED THE OUTPUT OR INPUT RATINGS, AS STATED IN THE SPECIFICATIONS.
PROTECT THE UNIT WITH PROPERLY RATED FUSES.
DO NOT INSTALL IN DAMP OR MOIST AREAS.

THIS DEVICE SHOULD BE INSTALLED AND SERVICED BY QUALIFIED PERSONNEL.

Installation Instructions

figure 1. Front Panel Controls

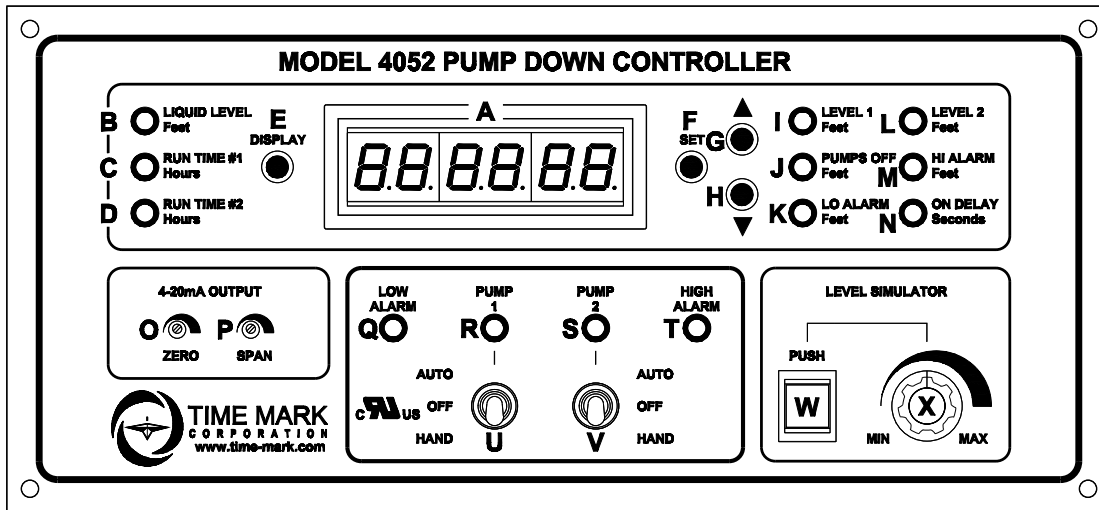

A	6 digit LED display	M	Indicates display is showing HIGH ALARM setting
B	Indicates display is showing LIQUID LEVEL	N	Indicates display is showing ON DELAY setting
C	Indicates display is showing PUMP #1 runtime	O	Controls ZERO setting for 4 to 20mA output
D	Indicates display is showing PUMP #2 runtime	P	Controls SPAN setting for 4 to 20mA output
E	Switches display between B, C and D	Q	Indicates LOW ALARM ACTIVE (low alarm relay-closed)
F	Push to enter SET mode	R	Indicates PUMP #1 RUNNING (pump #1 relay-closed)
G	Push ▲ to INCREASE setting	S	Indicates PUMP #2 RUNNING (pump #2 relay-closed)
H	Push ▼ to DECREASE setting	T	Indicates HIGH ALARM ACTIVE (high alarm relay-closed)
I	Indicates display is showing LEVEL 1 setting	U	3-position switch HAND-OFF-AUTO Pump #1
J	Indicates display is showing PUMPS OFF setting	V	3-position switch HAND-OFF-AUTO Pump #2
K	Indicates display is showing LOW ALARM setting	W	Momentary pushbutton engages LEVEL SIMULATOR
L	Indicates display is showing LEVEL 2 setting	X	Controls SIMULATED LEVEL (when SIMULATOR button is engaged)



TIME MARK
CORPORATION

11440 East Pine Street
Tulsa, Oklahoma 74116

Page 2 of 8 01/2017
© 2017 TIME MARK CORPORATION

TIME MARK is a division of  AEMT, Inc.

MODEL 4052

Pump Down Controller

figure 2. Back Panel Controls

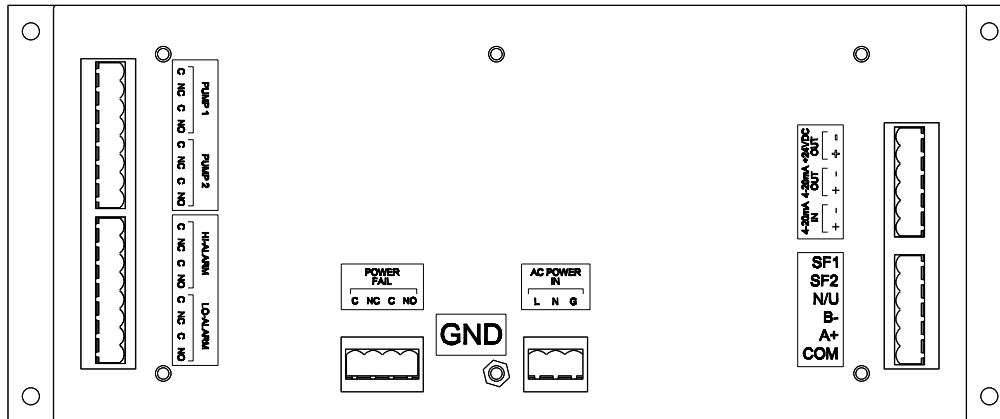

MOUNTING & WIRING

Mount the Model 4052 Pump-Down Controller in a panel or suitable enclosure (see Time Mark's **Model 4000 Surface Mount kit**).

Referring to the terminal block decals on the unit, and *Figure 2*, make the following connections:

SIGNAL INPUT

With a **3-wire** 4-20mA transducer (see Time Mark Model 450) remotely mounted, connect the +24VDC OUT terminal to the voltage input of the transducer (*figure 3*). Connect the 4-20mA IN terminals to the loop terminals of the transducer. **OBSERVE POLARITY.**

figure 3.

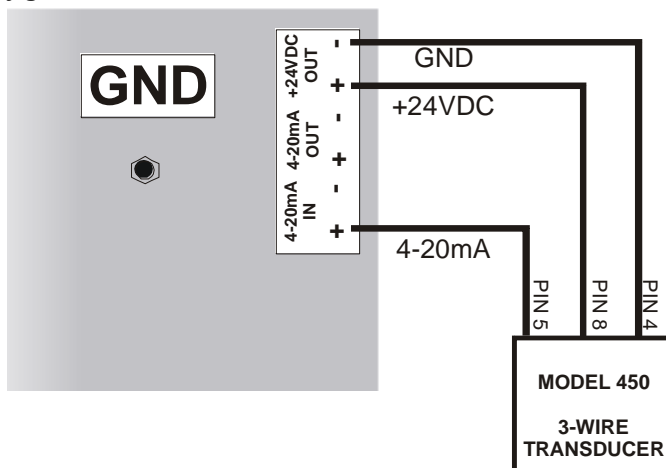

Connect a **2-wire** transducer (pressure, ultrasonic, etc.) as shown in *figure 4*.

figure 4.

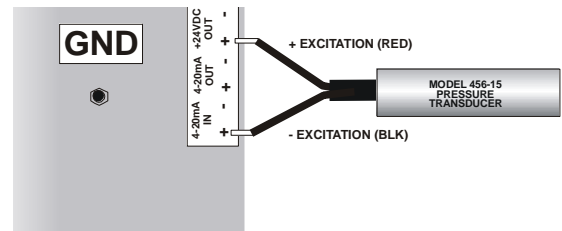

SIGNAL OUTPUT

The 4-20mA output is proportional to the input signal. This allows for very accurate remote monitoring of level changes. The factory default is for the output to track the input; that is, a 4mA signal represents 00.0 feet, and a 20mA signal represents 34.6 feet. However, the output can be zeroed and spanned to a specific range, not necessarily the same as the reading on the LED display.

The 4-20mA OUT terminals may be connected to a remote display or other devices. Connect these terminals as required for your application. **OBSERVE POLARITY** of the connections.

RELAY OUTPUTS

SPDT contacts are provided for PUMP 1, PUMP 2, HI-ALARM, LO-ALARM and POWER FAIL relays. Make wiring connections as required.

OPERATING POWER

Connect a chassis ground to the lug marked **GND** and the terminal marked **G**.

Connect 120VAC operating power to the terminals marked **L** (line) and **N** (neutral).



TIME MARK
CORPORATION

11440 East Pine Street
Tulsa, Oklahoma 74116

Page 3 of 8 01/2017
© 2017 TIME MARK CORPORATION

TIME MARK is a division of  **AEMT, Inc.**

MODEL 4052

Pump Down Controller

USER SELECTABLE PROBE SETTINGS

This unit is factory set to 15 psi. To change probe values, press and hold the following buttons while powering up:

Press & Hold	Result:			
SET	Use ▲ or ▼ keys to select probe values according to the chart below:			
	Display	Range PSI	Max Ft.	Max Display
	5	0-5	11.5	18
	10	0-10	23.0	30
	15*	0-15	34.6	40
	20	0-20	46.1	55
	30	0-30	69.2	75
	40	0-40	92.3	99.9
	50	0-50	115	120
	60	0-60	138	160
	70	0-70	162	175
	80	0-80	185	200
	90	0-90	208	225
	100	0-100	230	250
150	0-150	346	360	
▲ & ▼	Restore unit to factory settings*.			
DISPLAY	Select a Modbus address between 0—247 using the ▲ or ▼ keys. Unit is initially factory set to 1.			

Press Display to exit setup mode.

PROGRAMMING - SET mode

The Model 4052 Controller has been factory tested and calibrated. Factory settings are as follows:

HIGH ALARM	10.0 ft
LEVEL 2	8.0 ft
LEVEL 1	6.0 ft
PUMPS OFF	4.0 ft
LOW ALARM	2.0 ft

NOTE: Both Hand-Off-Auto (H.O.A.) switches MUST be in the OFF position before entering the SET mode.

To enter the SET mode, push the button marked SET

PROGRAMMING - SET mode (Cont'd)

The display will now show the LOW ALARM setpoint. Change the LOW ALARM setpoint to the desired level, using the ▲ or ▼ keys (figure 1 G,H) to the right of the SET button. After setting the LOW ALARM setpoint, press the SET button again. The display now shows the PUMPS OFF setting.

Using this same procedure, set the PUMPS OFF, LEVEL 1, LEVEL 2, and HIGH ALARM settings (in that order).

After setting the HIGH ALARM, press the SET button, to display the factory setting for the ON DELAY timer. Use the ▲ or ▼ keys (figure 1 G,H) to set the ON DELAY to the desired setting (0 to 30 seconds).

After setting the ON DELAY time period, press the SET button again to enter the setting into memory.

Review all settings by cycling through the setpoints before proceeding to the DISPLAY mode. Finally, press the DISPLAY button, to enter all settings into memory.

OPERATION - DISPLAY mode

While in DISPLAY mode, the LIQUID LEVEL is shown on the LED display. Pushing the DISPLAY button, while in the DISPLAY mode will change the LED display from LIQUID LEVEL to RUN TIME #1 to RUN TIME #2, and back to LIQUID LEVEL.

If the DISPLAY button is not pushed for 60 seconds, the LED display will automatically return to the LIQUID LEVEL setting.

NOTE: The LOW ALARM, PUMPS OFF LEVEL 1 and LEVEL 2 settings must move up in value from LOW ALARM to LEVEL 2, to be properly set.

The Model 4052 will not enter the DISPLAY mode if these settings are improper. When trying to move to the DISPLAY mode with improper settings, the LED display will automatically return to the SET mode. Adjust the improper setpoint, then continue.

The HIGH ALARM setpoint can be set anywhere within the scale.

VERIFYING SETTINGS

Before entering automatic operation, the program setting should be reviewed and verified using the following procedure.

While in the DISPLAY mode (with H.O.A. switched in the OFF position), the LEVEL SIMULATOR can be engaged.



TIME MARK
CORPORATION

11440 East Pine Street
Tulsa, Oklahoma 74116

Page 4 of 8 01/2017
© 2017 TIME MARK CORPORATION

TIME MARK is a division of  AEMT, Inc.

MODEL 4052

Pump Down Controller

VERIFYING SETTINGS (Cont'd)

Push the LEVEL SIMULATOR momentary push-button (*fig. 1 W*), and hold it down. The input to the external transducer will be disabled and internal level simulator will take its place.

Turning the potentiometer (*figure 1 X*), will simulate changes to the liquid level being monitored.

In this mode, simulated changes in liquid level will cause the alarm relays to open and close, the liquid level to change on the numeric display, and all LEDs to operate (PUMP 1 and PUMP 2 LEDs will flash).

NOTES: RETURN THE SIMULATOR KNOB TO THE **MINIMUM** SETTING BEFORE RELEASING THE SIMULATOR BUTTON. The PUMP 1 and PUMP 2 relays will not energize in the LEVEL SIMULATOR mode.

AUTOMATIC OPERATION

For fully automatic operation, set the display to monitor the liquid level, and move the HAND-OFF-AUTO switches to the AUTO position.

MANUAL OPERATION

To manually operate either of the pumps, push the momentary HAND-OFF-AUTO toggle switch for the appropriate pump down to the HAND position, and hold.

COMMUNICATION CONNECTOR

Pin	Label	Name
1	COM	Ground (Top Terminal)
2	A+	RS-485(A+)
3	B-	RS-485(B-)
4	N/U	Not Used
5	SF2	Seal Fail Pump 2 when grounded
6	SF1	Seal Fail Pump 1 when grounded

SEAL FAIL

For fully automatic operation

Connect one side of a normally open dry contact from seal fail sensor for pump 2 to pin 5 and the other to pin 1.

Run Time #2 will flash when contacts close and pump will operate normally.

Connect one side of a normally open dry contact from seal fail sensor for pump 1 to pin 6 and the other to pin 1.

Run Time #1 will flash when contacts close and pump will operate normally.

Note: Seal Fail monitoring is not available on the Model 4052MC configuration

RS-485 COMMUNICATION

See *Appendix A: RS-485 Communication* for RS-485 Communication settings.

WARRANTY

This product is warranted to be free from defects in materials and workmanship for one year. Should this device fail to operate, we will repair it for one year from the date of manufacture. For complete warranty details, see the *Terms and Conditions of Sales* page in the front section of the Time Mark catalog or contact Time Mark at 1-800-862-2875.



TIME MARK
CORPORATION

11440 East Pine Street
Tulsa, Oklahoma 74116

Page 5 of 8 01/2017
© 2017 TIME MARK CORPORATION

TIME MARK is a division of  AEMT, Inc.

MODEL 4052

Pump Down Controller

TYPICAL APPLICATION - Transducer

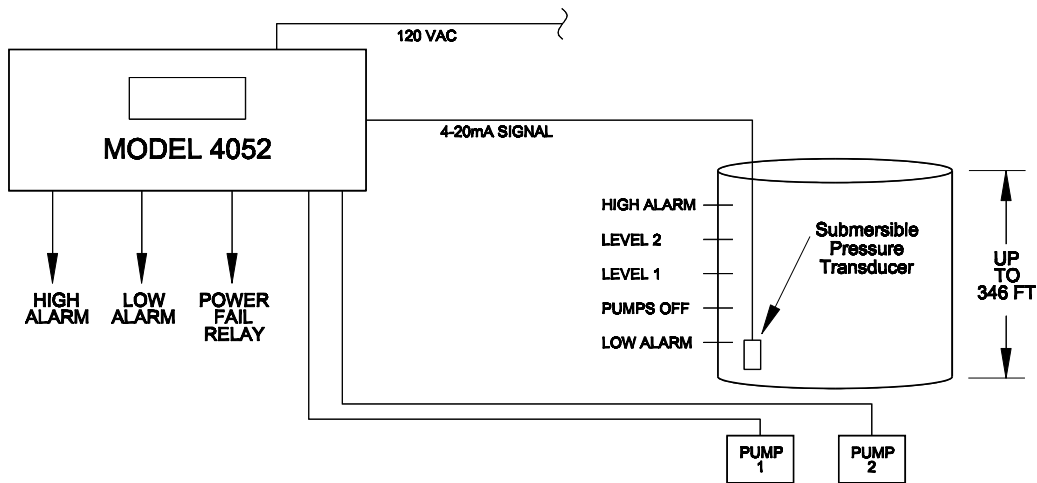

TYPICAL APPLICATION - Float Switches

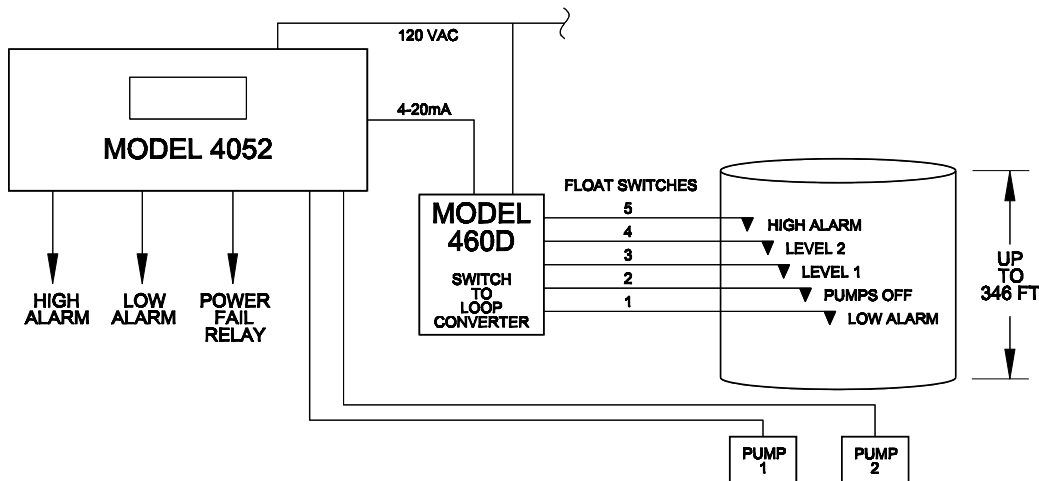

INSTALLATION WORKSHEET

JOB NAME:			DATE:
SETPOINTS	FACTORY SETTING	SET AT LEVEL:	NOTES
High Alarm	10 ft		
Level 2	8 ft		
Level 1	6 ft		
Pumps Off	4 ft		
Low Alarm	2 ft		



TIME MARK
CORPORATION

11440 East Pine Street
Tulsa, Oklahoma 74116

Page 6 of 8 01/2017
© 2017 TIME MARK CORPORATION

TIME MARK is a division of  AEMT, Inc.

MODEL 4052MC Optional Configuration

- Monitor Motor Control Contacts
- Disable Run Time Meters In Fault Condition

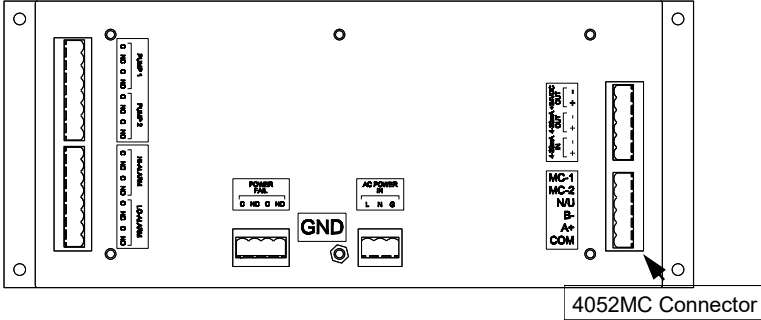

INSTALLATION DRAWING MC1/MC2 CONNECTIONS

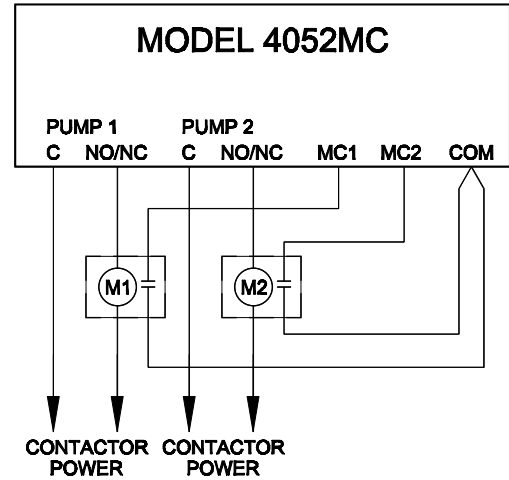

The 4052MC option replaces seal fail monitoring with motor starter monitoring. When the 4052MC calls for a pump to run the corresponding MC contact should close. If the MC contact closes, the pump controller will increment the run time for that pump. If the MC contact does not close, or opens after the pump has been started, the pump controller will not increment the run time for that motor and will flash the Run Time light on the left side of the controller for the corresponding pump.

MODEL 4000 Surface-Mount Kit

- 20 Ga. CRS Enclosure
- Removable Access Panel



Designed to easily install Time Mark Models **403, 404, 4042, 4052, 4062, or 408** Liquid Level Controllers.

This 20 gauge steel enclosure features a removable top panel for easy access to wiring connections. The mounting kit comes complete with everything you need, including steel support brackets. This model is designed specifically for applications that require surface-mounting these Time Mark Liquid Level Controllers.

For more information, see the full data sheet in the Time Mark standard products catalog.



TIME MARK
CORPORATION

11440 East Pine Street
Tulsa, Oklahoma 74116

Page 7 of 8 01/2017
© 2017 TIME MARK CORPORATION

TIME MARK is a division of  AEMT, Inc.

MODEL 4052

Pump Down Controller

APPENDIX A: RS-485 Communications

Connect RS-485 A+ to pin 2.
 Connect RS-485 B- to pin 3
 Connect RS-485 GND to pin 1

Modbus holding registers (Function 03)

Address	Register in Pump Controller
0	Level
1	Low alarm
2	Pumps off
3	Level 1
4	Level 2
5	High Alarm
6	On delay
7	Run time pump1 low 16 bits
8	Run time pump1 high 16 bits
9	Run time pump2 low 16 bits
10	Run time pump2 high 16 bits
11	Run time pump1 0.1 seconds
12	Run time pump2 0.1 seconds
13	System status

Bit	Decimal	Signal	If bit = 1
15	32768	L2ON	Level 2 is on
14	16384	L1ON	Level 1 is on
13	8192	L2EN	Level 2 is enabled
12	4096	L1EN	Level 1 is enabled
11	2048	ELED2	Pump 2 LED is on
10	1024	ELED1	Pump 1 LED is on
9	512	TESTF	Test button not pressed
8	256	SETF	Set mode
7	128	HAND_2	Pump 2 in HAND
6	64	AUTO_2	Pump 2 in AUTO -- 00 pump 2 off
5	32	HAND_1	Pump 1 in HAND
4	16	AUTO_1	Pump 1 in AUTO -- 00 pump 1 off
3	8	HI_AL	High alarm on
2	4	M2RUN	Pump 2 running
1	2	M1RUN	Pump 1 running
0	1	LO_AL	Low alarm on

- 14 Controller software version
- 15 Min low
- 16 Max high
- 17 Delta runtime pump1 low 16 bits
- 18 Delta runtime pump1 high 16 bits
- 19 Delta runtime pump2 low 16 bits
- 20 Delta runtime pump2 high 16 bits

RS-485 Communications (Cont'd)

Discrete Read (Function 02)
 Seal fail when bit = 1.

Address	Bit	Status
0	0	SEAL1
0	1	SEAL2

Coils Write (Function 05)
 Set coil to 1. Unit will perform function and reset coil.

Address	Bit	Function
0	0	Reset delta runtime pump1
0	1	Reset delta runtime pump2
0	2	Reset Max High and Min Low

